OPERATOR'S MANUAL

SPECTROLINE[®]
NDT X-Series
UV Bench and Display Lamps



LAMP CONTAINS MERCURY
Manage in Accordance with
Disposal Laws
See: www.lamprecycle.org



SPECTRO-UV

www.Spectro-UV.com

4 Dubon Ct., Farmingdale, NY 11735
866-230-7305

06/22 AM09041-5
Printed in U.S.A.



WARNING

**UV light emitted from this product. Avoid eye and skin exposure to unshielded products.
FOR PROFESSIONAL EXAMINATION USE ONLY**

GENERAL OPERATION

- To prevent breakage, the UV tubes for 40-watt lamps are not installed when shipped. Install according to the tube replacement instructions in the "OPERATOR SERVICING" section of this manual.
- For 15-watt lamps, install the two mounting brackets according to the instructions provided in their packing envelope.
- NOTE:** All other lamps have mounting brackets permanently attached.
- Connect the plug to a power outlet that complies with the electrical requirements specified on the lamp's label.
- The power supply cord is the disconnect for this unit.
- To light the lamp, move the ON/OFF toggle switch on the end of the lamp to the "ON" position.
- To turn off the lamp, move the switch to the "OFF" position.



WARNING

Please read instructions in this manual carefully before using your Spectroline® lamp. Never use this equipment in any manner not specified in these instructions because the protection provided by the equipment may be impaired. We recommend using Spectroline UV-absorbing protective eye and face wear. See Ordering Information for model numbers. This eye and face wear also improves contrast between the fluorescent area and the background and eliminates "blue haze" interference.

OPERATOR SERVICING

The following servicing instructions are intended for limited maintenance of the X-Series lamps. Do not perform any servicing other than that contained in these instructions. Return the lamp to the factory for other maintenance not covered in this section.

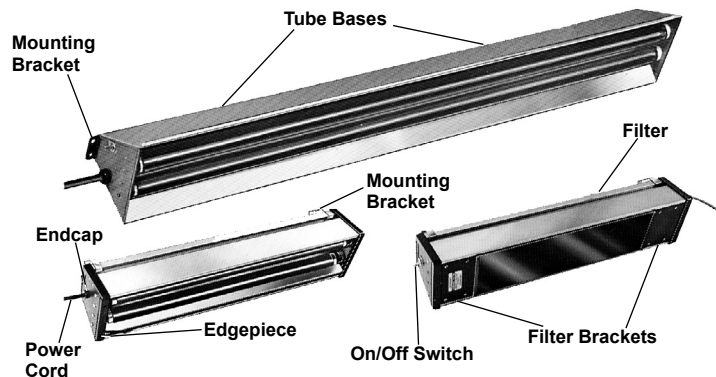

REPLACING THE UV TUBE(S)

- Unplug the lamp.
- For lamps without filters, proceed to step 4. For lamps with filters, detach the slim plastic edgepiece from the lamp's endcap (on the end with the power cord) by removing its two holding screws.
NOTE: Do not remove the endcap itself, which has four screws in it.
- Carefully slide out the filter assembly (filter and attached metal brackets and frame). Gently set it aside on a flat surface.
- To replace a faulty tube, hold it by the metal bases located at either end. Rotate the tube slightly and gently lift it from the sockets. Install the new tube by reversing this procedure.
- Where applicable, replace filter assembly by reversing the procedure in steps 2 and 3.
- Plug in the lamp and test the function of the new tube(s).

REPLACING THE FILTER

- Unplug the lamp.
- Remove the eight holding screws attaching the two filter brackets to the filter frame.
- Remove the brackets by gently prying them upward with a flathead screwdriver or similar tool.
- Lift off and set aside the filter.
- Carefully install the new filter in the same position as the original filter, with the smooth surface facing outward.
- Snap the brackets back into position and replace all screws.

ENVIRONMENTAL SPECIFICATIONS

The Spectroline X-Series lamps are designed to be safe under the following conditions:

- Indoor use;
- Altitude up to 2,000 m (6,562 ft.);
- Temperature 5°C to 40°C (41°F to 104°F);
- Maximum relative humidity 80% for temperatures up to 31°C (88°F) decreasing linearly to 50% relative humidity at 40°C (104°F);
- Mains supply voltage fluctuations not to exceed ±10% of the nominal voltage;
- Installation Category II;
- Pollution Degree

ELECTRICAL SPECIFICATIONS

Model	Wavelength	Equipped With	120V, 60Hz Amps
X-15A	UV-A	One 15W BLB Tube	0.40
XX15A	UV-A	Two 15W BLB Tubes	0.70
X-15N	UV-A	One 15W BL Tube, Filter Assembly	0.40
XX-15N	UV-A	Two 15W BL Tubes, Filter Assembly	0.70
X-30	UV-A	One 30W BLB Tube	0.80
X-40	UV-A	One 40W BLB Tube	0.60
XX-40	UV-A	Two 40W BLB Tubes	1.60
XX-40N	UV-A	Two 40W Tubes, Filter Assembly	1.60
X-15B	UV-B	One 15W Tube/ONGLIFE Filter	0.40
XX-15B	UV-B	Two 15W Tubes, LONGLIFE Filter	0.70
X-15F	UV-C	One 15W Tube, LONGLIFE Filter	0.40
XX-15F	UV-C	Two 15W Tubes, LONGLIFE Filter	0.70
XX-15NF	UV-A/UV-C	Two 15W Tubes, LONGLIFE Filter	0.70
XX-15BF	UV-B/UV-C	Two 15W Tubes, LONGLIFE Filter	0.70
XX-15NB	UV-A/UV-B	Two 15W Tubes, LONGLIFE Filter	0.70
X-15W	White Light	One 15W White Light Tube	0.40
XX-15W	White Light	Two 15W White Light Tubes	0.70
X-15G	UV-C	One 15W Clear Tube (Germicidal)	0.40
XX-15G	UV-C	Two 15W Clear Tubes (Germicidal)	0.70
X-30G	UV-C	One 30W Clear Tube (Germicidal)	0.80

Long Wave (UV-A) 365nm Medium Wave (UV-B) 312nm Short Wave (UV-C) 254nm

WARRANTY

The warranty policy for the X-Series UV lamps is provided on the Certificate of Limited Warranty enclosed separately with each unit.

NOTE: For assistance of any kind, contact the Customer Service Department at Spectro-UV. Call toll-free 1-866-230-7305. Give full details of the difficulty and include the model and serial numbers of the unit and the date of purchase. If return of the unit to the factory is deemed necessary, shipping instructions will be provided. If an estimate of charges for nonwarranty work or other service work is required, a quote will be furnished upon evaluation of the unit. Out-of-warranty service work will not be performed without customer approval.

SHIPPING

Carefully pack the unit in its original shipping container and packing materials and ship it prepaid to the factory. Insure it for full value.

ORDERING INFORMATION

Description	Part No.
Tube—365nm 15W BLB	BLE-1800B
Tube—365nm 15W BL	BLE-1T151
Tube—254nm 15W	BLE-1T155
Tube—312nm 15W	BLE-1T158
Tube—254nm 30W	BLE-1T305
Tube—White Light 15W	BLE-1T535
Tube—365nm 30W BLB	BLE-5000B
Tube—365nm 40W BLB	BLE-7900B
Filter—X-15N, XX-15N	2F501
Filter—15W 254nm, 312nm, Multi-Band Lamps	2F508
Filter—40W XX-40N (Two Required)	2F951
Spectacles, UV-Absorbing	UVS-30
Goggles, UV-Absorbing	UVG-50
Face Shield, UV-Absorbing	UVF-80

Distributed by:



800-900-9097

www.NDTUnlimited.com

info@NDTUnlimited.com



www.Spectro-UV.com

4 Dubon Ct., Farmingdale, NY 11735

866-230-7305